

## Optimal Location and Sizing of IPC and SVC in Power Systems by Genetic Algorithm (GA) For Power Losses Minimization

Behrouz Najafi<sup>1\*</sup>

1- Department of Electrical Engineering, Gonabad branch, Islamic Azad University, Gonabad, Iran

[\\*behroz1.najafi1@gmail.com](mailto:behroz1.najafi1@gmail.com)

Received: July 2017

Accepted: August 2017

### Abstract

In this paper, we have discussed about the study of Flexible AC Transmission Systems (FACTS) devices in power system to reduce active power losses which are important factor to restrict transmitted power in the network. For this study, static var compensator (SVC) and Interphase Power Controller (IPC) are chosen as the compensator devices. This paper presents about the effective localization and sizing of the SVC and IPC in power system by a global search GA (Genetic Algorithm) technique. Ultimate goal is to improve the stability of power system as well as to reduce the transmission losses by increasing loadability and improving voltage profile with introduce FACTS device at the most effective region. Simulations are implemented using MATLAB and Matpower software package. Simulation is carried out on IEEE 30-bus system. Results are presented which demonstrate the effectiveness of the proposed techniques.

Keywords: Optimal Location, Optimal Power Flow, IPC, SVC, Reduce Losses.

### 1. Introduction

Power losses in electric power grids represent one of the main factors of electric power systems (EPS) performance. Thus, the loss minimization is a topical issue when designing, operating and upgrading power grids. The investigation of issues pertaining to power loss minimization in electric grids as a mean of optimized EPS operation is one of current trends of scientific efforts.

The study various sources indicate that different methods to reduce losses, divided into two general categories: FACTS Devices -based methods and Other methods.

The "first- class methods " can include the following:

- 1) In [16], reduction of active power losses and voltage regulation are done by optimal capacitor location.
- 2) In [17], the reorganization of distribution networks has been introduced as a method for reducing losses.

The " Second-class methods" can include the following:

- 1) In [18], the Newton-Raphson algorithm has been used to investigate the effect of UPFC on power flow and reduce losses in a power system.
- 2) The issues pertinent to the reduction of active power losses in electric power systems (EPS) are studied in [19],The method presented in this article is based on EPS clustering upon FACTS influence zones.
- 3) The optimal location for UPFC and IPFC controllers to reduce losses is another effort that researchers have reported in this regard [20].

4) In [21], the losses reduction has been investigated using Interline Power Flow Controller (IPFC). For optimal placement and optimal setting of IPFC parameters, Particle Swarm Optimization (PSO), differential evolution (DE) and bone colony (ABC) algorithms have been compared.

The results of the research literature indicate that Different methods have been proposed for optimal placement and proper parameter setting of FACTS devices with several objective functions in the literature.

The focus of this research is placed On first methods. FACTS Devices As active and reactive power flow controllers, have a High flexibility in power control the EPS, Helped in solving the problem of losses, and They will be cause Reduce Significant losses in power systems as well as decrease production costs, and permit optimal use of existing System capacity.

FACTS devices have been used in power systems since the 1970s with the objective of improving system dynamic performance. But the practical implementation and development of new analytical procedures are still in evolution.

Optimal Placement of FACTS devices in Optimal operation of the power system is very important. at problem of optimal placement of FACTS devices should be noted to Four point:

**a) Suitable element:**

Type element depends on goal that is expected of the element. If main purpose is control of active power flow in transmission lines, The series devices can be a good choice. If the main goal is to maintain voltage and reactive power control, The shunt elements can be a good option. If the main purpose is Integrated control and at the same time of Power flow and voltage. The combined series-shunt controllers Can be a suitable choice.

**b) suitable size**

It is depends on two factors: Investment cost and Technological constraints.

**c) Suitable place:**

It is depends on the electrical characteristics studied network.

**d) Suitable cost:**

Should be compared to the investment and maintenance costs of FACTS devices with Costs related to general and older devices, Then decide on the installed or not installed FACTS element.

determining each of these cases is essential in placement the FACTS equipment. It is entirely influenced by the Conditions and objectives that are at problem. Among the different methods, the heuristic optimization techniques have been widely applied in solving the optimal FACTS placement problem. In this work, we used of Genetic Algorithm.

## 2. FACTS Devices Modeling

FACTS devices are being utilized to achieve many objectives in an electric power system. . Main ability of FACT devices is fast and effective control of various variables in power transmission networks [14]. According to available information in [15] in terms of placement of FACTS devices in the network are divided into three categories (We've only used two different types of these devices) ;

**a) Series devices:**

These devices are placed in series with the transmission line and usually by changing the reactance of the transmission line are able to control power flow in lines [1]. In this paper used from one of the newest power flow controllers, the name of Interphase Power Controller (IPC).

**b) Shunt devices :**

These devices are connected to a bus of system and they control the voltage of point of connection by injecting or absorbing reactive power into or from the system [1]. Static var compensator (SVC) is the most common type of these devices, which In this paper We have applied.

**c) Series-shunt devices:**

These devices are combination of two previous types [1]. unified power flow controller (UPFC) is the most common type of these devices. We have not used this type.

## 2.1. IPC Model

Inter-Phase Power Controller (IPC) is an multi-functional device, which has many capabilities such as power flow control, fault current limitation and voltage isolation [2–4]. On the same basis and depending on their application and technique used to implement the phase shifts of the internal voltages various topologies have been suggested [2–5]. A general model of IPC is shown in Fig. 1. As shown in this figure, each phase consists of two parallel branches and each branch contains a reactance (inductor or capacitor) connected in series with the phase-shifting device. In this topology the IPC control variables as follows: (reactance, internal phase angles, or both.

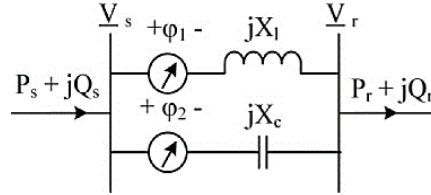

Fig. 1. IPC model

We use tuned IPC, which has equal reactance for the inductor and capacitor. Based on the method presented in [2] for IPC modeling, power injection model. may be introduced as shown in Fig. 2.

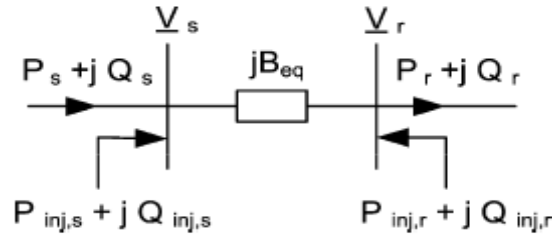

Fig. 2. IPC power injection model.

In this figure,  $P_{inj,k}$  and  $Q_{inj,k}$  ( $k = s$  and  $r$ ) are active and reactive power injections at buses  $s$  and  $r$ , respectively. They can be calculated by the following equations:

$$\begin{aligned}
 P_{inj,s} &= -V_s^2 \sum_{k=1,2} B_{eqk} \sin(f_k) \\
 Q_{inj,s} &= -V_s^2 B_{eq} + V_s^2 \sum_{k=1,2} B_{eqk} \cos(f_k) \\
 P_{inj,r} &= -V_s V_r \sum_{k=1,2} B_{eqk} \sin(\delta_{sr} - \phi_k) + V_s V_r B_{eqk} \sin(\delta_{sr}) \\
 Q_{inj,r} &= -V_s V_r \sum_{k=1,2} B_{eqk} \cos(\delta_{sr} - \phi_k) + V_s V_r B_{eqk} \cos(\delta_{sr})
 \end{aligned} \tag{1}$$

In this equation  $B_{eqk}$  ( $k=1$  and  $2$ ) is susceptance of each branch. In the case of the tuned IPC, we have  $B_{eq}=0$ .  $V_s, V_r, \phi_s, \phi_r$  are voltage amplitudes and angles of IPC input and output buses respectively. consequently  $\phi_s, \phi_r$  the same phase shift angles.  $\delta_{sr}$ , is angle between buses  $s$  and  $r$  as follows:

$$\delta_{sr} = \phi_s - \phi_r \tag{2}$$

## 2.2. SVC Model

SVC is a shunt connected devices used to absorb reactive power from the bus or to inject reactive power to the bus where it is connected. [6–9] SVC is parallel combination of capacitor and inductor and static model of SVC is shown in Fig. 3

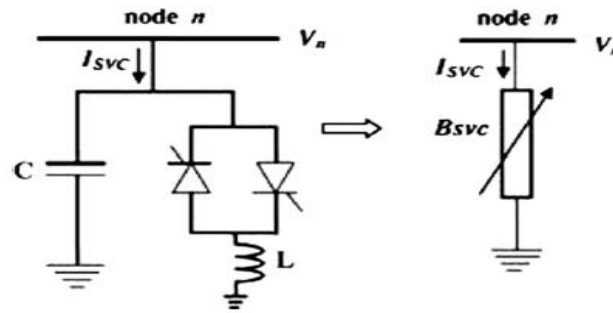

Fig. 3. Static model of SVC.

According to [9] SVC can be used as a variable parallel susceptance as shown in Fig. 3. Equations expressing the absorbed current and reactive power by SVC will be as follows:

$$\begin{aligned} I_{SVC} &= jB_{svc}V_n \\ Q_{SVC} = Q_K &= -jB_{SVC}V_n^2 \end{aligned} \quad (3)$$

Where  $I_{SVC}$  is absorbed current by SVC,  $B_{SVC}$  is susceptance of SVC,  $Q_{SVC}$  is absorbed reactive power by SVC that is equal to injected power into connective bus n and  $V_n$  is the bus voltage where SVC is connected.

### 3. Location and sizing of FACTS devices Methodology:

The best location, appropriate size and setting of FACTS devices are important in the deregulated electricity markets. The location of FACTS devices can be based on static and/or dynamic performance of the system. The best placement of FACTS controllers to improve the dynamic performance requires the eigen value analysis and time domain simulation with proper dynamic modeling of FACTS controllers. From static point of view, the placement of FACTS devices is to reduce the congestion and/or system losses [10].

Sizing of FACTS devices is also important because cost of FACTS device is proportional to size. The sizing problem during the planning stage is to find the optimum size which gives the desired control objectives and at the same time with minimum investment. It is also necessary to assure the secure operation of the network for the likely transactions during the planning horizon and has the capacity to support the network during worst contingencies [10].

#### 3.1. Optimization Algorithm(Genetic Algorithm):

A genetic algorithm (GA) is a method for solving both constrained and unconstrained optimization problems based on a natural selection process that mimics biological evolution. Actually Genetic Algorithm (GA) has been the most popular technique in evolutionary computation research That repeatedly modifies a population of individual solutions. At each step, the genetic algorithm randomly selects individuals from the current population and uses them as parents to produce the children for the next generation. Over successive generations, the population "evolves" toward an optimal solution[11].

A GA is a search procedure inside a problem's solution domain. Since examining all possible solutions of a specific problem is usually considered infeasible, GAs offer an optimization heuristic inspired by the theory of natural selection. First, an initial population of candidate solutions, also called chromosomes, is randomly generated. Every chromosome is a complete solution to the problem, e.g. a suggested arrangement of the puzzle's pieces. Next, various biologically inspired operators such as selection, reproduction and mutation are applied. These operators gradually improve the solutions in the population, eventually reaching the optimum solution. In order to imitate natural selection, a chromosome's reproduction rate, i.e. the number of times it is selected to reproduce and hence the number of its offsprings, is set directly proportionate to its fitness. The fitness is a score obtained by a fitness function and it represents the quality of a given solution. Thus, "good" solutions will have relatively more offsprings than other solutions. Moreover, good chromosomes are more likely to reproduce with other good chromosomes. The reproduction operator, called crossover, should allow the better traits from both parents to be passed on and be combined into the child solution, potentially creating an improved solution. The success of a GA is mainly dependent on choosing an appropriate chromosome representation, crossover operator, and fitness function. The chromosome representation and crossover operator must allow the merge of two good solutions to an even better solution. The fitness function must correctly detect chromosomes containing promising solution parts to be passed on to the next generations [11].

Steps in Basic Genetic Algorithm [12]:

- Step 1: [Start] Define the fitness function  $f(x)$  according to the problem definition.
  - Step 2: [Initialise] Generate random population of  $n$  chromosomes – each chromosome being the potential solution.
  - Step 3: [Fitness] Evaluate the fitness  $f(x)$  of each chromosome  $x$  in the population.
  - Step 4: [New population] Repeat the following steps to create the new population of chromosomes:  
 [Selection] Select some parent chromosomes from a population according to their fitness to form mating pool  
 [Crossover] Mate the selected chromosomes as per given crossover probability to form new offsprings.  
 [Mutation] Mutate new chromosomes as per given mutation probability.  
 [Replace] Replace the old population of chromosomes with the new population.
  - Step 5: [Convergence check] If the maximum number of generations is reached, then stop, and return the best solution.
  - Step 6: [Loop] Go to step 3
- Basic flowchart of Genetic Algorithm is shown in Fig. 4.

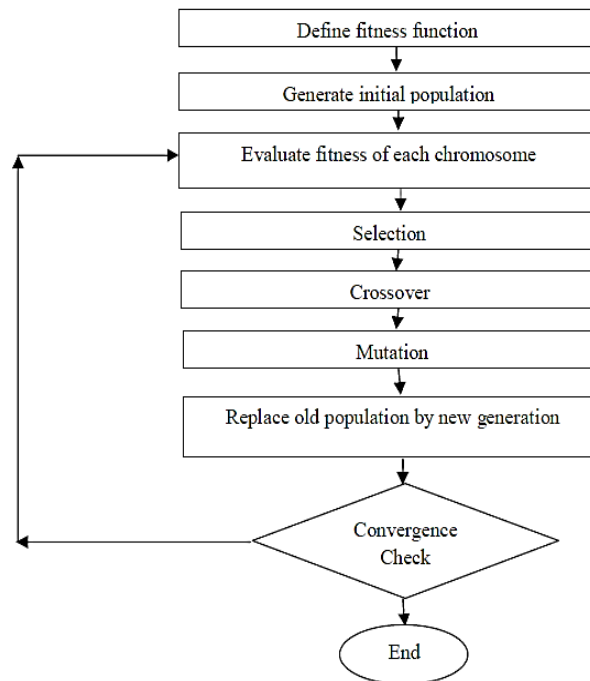

Fig. 4. Basic flowchart of genetic algorithm.

### 3.2. GA Parameters:

GA parameters used in this work are taken in table 1.

Table 1. GA parameters

Number of generations	100
Population size	100
Crossover probability	0.8
Mutation probability	0.05
Type of selection	Tournament
StallGenLimit	100
Stall time Limit	1000

### 4. Problem Statement

The goal of optimization was the determination of optimal Location of FACTS devices into a power system in order to reduce system losses. Therefore, the presented problem becomes a single -objective optimization problem (SOP), and this can be expressed, in equation form, as:

$$\begin{aligned}
 & \text{Minimize} && f(x) \\
 & && h_i(x) = 0 \quad i = 1, 2, 3, \dots, n \\
 & \text{Subject to :} && g_i(x) \leq 0 \quad i = 1, 2, 3, \dots, m \\
 & && X_{min} \leq X \leq X_{max}
 \end{aligned} \tag{4}$$

Where  $f(x)$  is objective function,  $h_i(x)$  and  $g_i(x)$  are the equality and inequality problem constraints respectively,  $X$  is Vector optimization variables.

#### 4.1. Objective Function

The objective function is included only network losses that it should be minimized. To define the objective function, the Total active losses of network before installation FACTS equipment ( $P_{loss1}$ ) Compared with the Total active losses of network After installation FACTS equipment ( $P_{loss2}$ ) as follows:

$$F = \frac{P_{loss2}}{P_{loss1}} \tag{5}$$

In this paper, Losses determined using OPF program Matpower toolbox in Matlab software and The Newton-Raphson method.

#### 5. Optimal Power Flow (OPF) Formulation

Problem Constraints are classified into three types equality constraints, inequality constraints, and constraints related to the capacity of FACTS devices, as follows:

- **Power balance equation Without FACTS Devices :**

$$\begin{aligned}
 P_i(\theta, V) - P_G + P_D &= 0 \quad \text{for anynode } i \\
 Q_i(\theta, V) - Q_G + Q_D &= 0 \quad \text{for anynode } i
 \end{aligned} \tag{6}$$

- **Power balance equation With FACTS Devices :**

$$\begin{aligned}
 P_i(\theta, V) - P_{G_i} + P_{D_i} + P_i^F &= 0 \quad \text{for node } i, \\
 Q_i(\theta, V) - Q_{G_i} + Q_{D_i} + Q_i^F &= 0 \quad \text{for node } i, \\
 P_j(\theta, V) - P_{G_j} + P_{D_j} + P_j^F &= 0 \quad \text{for node } j, \\
 Q_j(\theta, V) - Q_{G_j} + Q_{D_j} + Q_j^F &= 0 \quad \text{for node } j,
 \end{aligned} \tag{7}$$

Where in equations (6) and (7),  $P_i^F, Q_i^F, P_j^F, Q_j^F$  are same,  $P_{inj, s}, Q_{inj, s}, P_{inj, r}$  and  $Q_{inj, r}$  ( active and reactive power injections at buses  $s$  and  $r$ , respectively),  $P_{G_i}, Q_{G_i}$  are the active and reactive power generation at node  $i$ ,  $P_{D_i}, Q_{D_i}$  are the active and reactive power load at node  $i$ ,  $P_i, Q_i$  are the net active and reactive power injection at node  $i$ .

- **Apparent line flow limit:**

$$S_{line, i} \leq S_{line, i}^{\max} \quad i = 1, 2, \dots, n_l \tag{8}$$

Where  $S_{line, i}$  are the apparent power flow in transmission line connecting nodes  $i$ , and  $S_{line, i}^{\max}$  is its maximum limit.

- **Power generation limit**

$$\begin{aligned} p_{Gi}^{\min} \leq p_{Gi} \leq p_{Gi}^{\max} & \quad i=1 \dots n_g \\ Q_{Gi}^{\min} \leq Q_{Gi} \leq Q_{Gi}^{\max} & \quad i=1 \dots n_g \end{aligned} \quad (9)$$

Where  $p_{Gi}^{\min}, p_{Gi}^{\max}$  minimum and maximum active power generation are limits of generating unit at bus  $i$ ,  $Q_{Gi}^{\min}, Q_{Gi}^{\max}$  are minimum and maximum reactive power generation limits of generating unit at bus  $i$ .

• **Bus voltage limit**

$$v_i^{\min} \leq v_i \leq v_i^{\max} \quad i=1 \dots n_b \quad (10)$$

$V_i^{\min}$  and  $V_i^{\max}$  are minimum and maximum voltage limits at bus  $i$ ,  $V_i^{\min}$  and  $V_i^{\max}$  was selected 0.95 pu and 1.05 pu respectively.

• **FACTS devices constraints**

$$\begin{aligned} 0 \leq Q_{SVC} \leq Q_{SVC, \max} \\ X_{L,IPC} = X_{C,IPC} = 150\Omega \end{aligned} \quad (11)$$

Where  $X_{L,IPC}, X_{C,IPC}$  are inductive and capacitive reactances,  $Q_{SVC}$ , is absorbed reactive power by SVC, Which is equal to injected reactive power by SVC into the bus which is connected.  $Q_{SVC, \max}$ , is its maximum limit.

**6. Optimization Variables**

Genetic algorithm works on the basis of chromosomes. for use of the capabilities genetic algorithm, Must be designed carefully chromosomes. Optimization variables for each chromosome contains Optimal Location Each device And control parameters of the device. control parameters tuned IPC includes phase-angle( $\phi_1$  and  $\phi_2$ ) But the strategy used in this study is Use the apparent power and reactive variables instead of variables ( $\phi_1$  and  $\phi_2$ ). For IPC ,Suggested chromosome structure is composed of three genes,and is shown in Fig. 5.

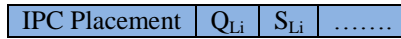

**Fig. 5.Chromosome structure proposed for IPC**

$Q_{Li}$  and  $S_{Li}$  are Reactive and apparent power line that gives us chromosome. The range of these variables is as follows:

$$\begin{aligned} 1 \leq IPC \text{ Placement} \leq N_{Line} \\ -0.1 \leq Q_{li} \leq 0.1 \\ -1 \leq S_{li} \leq 1 \end{aligned} \quad (12)$$

$N_{Line}$  is The number of lines in the test system.

Chromosome structure proposed for SVC is composed of two genes,and is shown in Fig. 6.

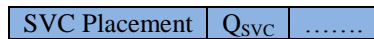

**Fig. 6.Chromosome structure proposed for SVC**

$Q_{SVC}$  is injected reactive power by SVC into the bus which is connected. The range of these variables is as follows:

$$\begin{aligned} 1 \leq SVC \text{ Placement} \leq N_{Bus} \\ 0 \leq Q_{SVC} \leq 100MVAR \end{aligned} \quad (13)$$

$N_{BUS}$  is The number of Bus in the test system.

### 7. Test system

The IEEE 30-bus test system is used. It has 41 lines, 30-buses and 6generators. Generators are located in buses 1,2,13,22,23,27. [13]. Single line diagram of the IEEE 30-bus test system given in Fig. 7.

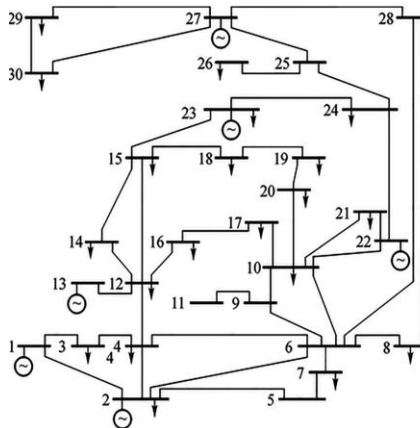

Fig. 7. Single line diagram of IEEE 30 bus system.

Also Network data of the IEEE 30-bus test system given in table .2.

Table 2. Network data of the IEEE 30-bus test system

Line No.	From	To	X (p.u.)	Flow limit (MW)	Failure rate	Repair rate
1	1	2	0.06	130	0.9783	0.0217
2	1	3	0.19	130	0.9841	0.0159
3	2	4	0.17	65	0.9532	0.0468
4	3	4	0.04	130	0.9172	0.0828
5	2	5	0.20	130	0.9786	0.0214
6	2	6	0.18	65	0.9497	0.0503
7	4	6	0.04	90	0.9828	0.0172
8	5	7	0.12	70	0.9760	0.0240
9	6	7	0.08	130	0.9211	0.0789
10	6	8	0.04	32	0.9494	0.0506
11	6	9	0.21	65	0.9494	0.0506
12	6	10	0.56	32	0.9211	0.0789
13	9	11	0.21	65	0.9535	0.0465
14	9	10	0.11	65	0.9509	0.0491
15	4	12	0.26	65	0.9660	0.0340
16	12	13	0.14	65	0.9838	0.0162
17	12	14	0.26	32	0.9754	0.0246
18	12	15	0.13	32	0.9598	0.0402
19	12	16	0.20	32	0.9510	0.0490
20	14	15	0.20	16	0.9494	0.0506
21	16	17	0.19	16	0.9494	0.0506
22	15	18	0.22	16	0.9236	0.0764
23	18	19	0.13	16	0.9514	0.0486
24	19	20	0.07	32	0.9509	0.0491
25	10	20	0.21	32	0.9666	0.0334
26	10	17	0.08	32	0.9824	0.0176
27	10	21	0.07	32	0.9786	0.0214
28	10	22	0.15	32	0.9612	0.0388
29	21	22	0.02	32	0.9462	0.0538
30	15	23	0.20	16	0.9498	0.0502
31	22	24	0.18	16	0.9506	0.0494
32	23	24	0.27	16	0.9181	0.0819
33	24	25	0.33	16	0.9483	0.0517
34	25	26	0.38	16	0.9537	0.0463
35	25	27	0.21	16	0.9733	0.0267
36	28	27	0.40	65	0.9818	0.0182
37	27	29	0.42	16	0.9808	0.0192
38	27	30	0.60	16	0.9564	0.0436
39	29	30	0.45	16	0.9537	0.0463
40	8	28	0.20	32	0.9537	0.0463
41	6	28	0.06	32	0.9536	0.0464



## 8. Process Simulation

The suggested method is programmed under MATLAB software and MATPOWER toolbox is used for optimal power flow (OPF) simulations.

Simulations implemented in two phases over the testing system.

phase one: Determining system losses without FACTS

phase two: Determining system losses with FACTS

FACTS devices have been installed in the system only individually.

Then phase one is compared to phase two.

## 9. Simulation Results

The main objective of this paper is to reduce active power losses in the transmission system using a IPC or SVC individually.

The results of the simulation output, after 10 times running genetic algorithms for the minimum value of the objective function, as follows:

**Table 3. IPC optimal placement results**

IPC Placement(line)	33	$\phi_1$ (Deg)	-87.1207
$Q_{Li}$ (P.U)	-0.062705	$\phi_2$ (Deg)	-86.6321
$S_{Li}$ (P.U)	0.063140	$P_{LOSS1}$ (MW)	2.8693
Objective Function	0.7908	$P_{LOSS2}$ (MW)	2.2691

With installation the IPC in line 33, between bus 24 and bus 25, is reduced system losses at a rate of 20.92 percent.

" $P_{LOSS1}$ " and " $P_{LOSS2}$ " represent active power loss before and after installing IPC in the system, respectively.

**Table 4. SVC optimal placement results**

SVC Placement(bus)	9	$V_{min1}$ (p.u)	0.9586
$Q_{SVC}$ (MVAR)	39.33	$V_{min2}$ (p.u)	0.9649
$P_{LOSS1}$ (MW)	2.8693	Objective Function	0.8812
$P_{LOSS2}$ (MW)	2.5286	iteration	20

With installation the SVC in bus number 9, is reduced system losses at a rate of 11.88 percent.

The minimum amplitude of bus voltages before and after the installation of the devices are respectively:  $V_{min1}$ (p.u) and  $V_{min2}$ (p.u), Which has increased from 0.9586 to 0.9649. Therefore, the voltage profile has been improved SVC is operated by injecting reactive power equal to 39.33 MVAR into bus 9.

## 10. Conclusion

In this paper investigated the effect of Implements IPC and SVC (which are the FACTS Devices series and Shunt respectively) on the power system losses. and Genetic Algorithm is used to determine the appropriate location. The results show that selective FACTS devices has a positive impact on the power system losses. And by determining the optimal location for them, significantly reduced total system losses.

because fault current limitation is the inherent capabilities of tuned IPC, Therefore, another important result achieved in this case: In addition to reducing total system losses, tuned IPC also provides fault current limitation, and this shows advantages IPC in Compared with other FACTS Devices .

Improved voltage profile, by installing SVC in bus number 9 .

another basic advantages of the proposed method compared to previous methods are as follows:

Simply Problem analysis, satisfy all constraints of equality and inequality, achieving optimal operating point.

## 11. References

1. Hingorani N.G, Gyugyi L(2000). "Understanding FACTS - Concepts and Technology of Flexible AC Transmission Systems". New York. IEEE Press.

2. Pourhossein, J. Gharehpetian, G. & Fathi, S. (2012). "Static Inter-Phase Power Controller (SIPC) Modeling for Load Flow and Short Circuit Studies". *Energy Conversion and Management*, 64, pp. 145-151.
3. Pourhossein, J. Gharehpetian, G. & Fathi, S.H. (2012). "Unified Interphase Power Controller (UIPC) Modeling and Its Comparison with IPC and UPFC". *Power Delivery, IEEE Transactions on*, 27, pp. 1956-1963.
4. Pourhossein, J. Gharehpetian, G. & Fathi, S.H. (2014). "Static Inter-Phase Power Controller Modeling and Its Comparison with IPC and SSSC". 6th Iranian Conference on Electrical & Electronics Engineering, ICEEE.
5. Beauregard F, Brochu J, Morin G, & Pelletier P. (1994). " Interphase power controller with voltage injection". *IEEE Transaction PWRD*. vol.13. 1956-1962.
6. Udir S, Srivastava L, & Pandit M. (2014). "Optimal placement and sizing of SVC for loss minimization and voltage security improvement using differential evolution algorithm". *Recent Advances and Innovations in Engineering (ICRAIE)*.
7. Dheebika S.K & Kalaivani R. (2014). " Optimal location of SVC, TCSC and UPFC devices for voltage stability improvement and reduction of power loss using genetic algorithm". *International Conference on Green Computing Communication and Electrical Engineering (ICGCCEE)*. 1-6.
8. Sedighzadeh M, Faramarzi H & Faramarzi S, (2013). "OPTIMAL LOCATION AND SETTING OF FACTS DEVICES USING NON-DOMINATED SORTING PARTICLE SWARM OPTIMIZATION IN FUZZY FRAMEWORK". *International Journal on "Technical and Physical Problems of Engineering" (IJTPE)*.
9. Biplab, B. Vikash, K. & Sanjay, K. (2014). "UPFC with series and shunt FACTS controllers for the economic operation of a power system". *Ain Shams Engineering Journal*, 5. 775-787
10. Acharya N & Mithulananthan N. (2006). " Locating series FACTS devices for congestion management in deregulated electricity markets". *Electric Power Systems Research*. vol.77. 352-360.
11. Sholomon, D. David, O. Netanyahu, N.S. (2013). "A Genetic Algorithm-Based Solver for Very Large Jigsaw Puzzles". *IEEE Conference on Computer Vision and Pattern Recognition*, 1767 - 1774.
12. Jyotishree. (2015). "Knowledge Based Operation And Problems Representation In Genetic Algorithms" Thesis Submitted to Kurukshetra University (INDIA).
13. IEEE 30-bus test system data. Available from: <[http://www.ee.washington.edu/research/pstca/pf30/pg\\_tca30bus.htm](http://www.ee.washington.edu/research/pstca/pf30/pg_tca30bus.htm)>.
14. Galiana F.D. & et all. (1996). "Assessment and Control of the Impact of FACTS Devices on Power System Performance". *IEEE, Trans. PWRD*. Vol. 11, 0, 4.
15. S. Sutha & N. Kamaraj. (2008). " Optimal Location of Multi Type Facts Devices for Multiple Contingencies Using Particle Swarm Optimization". *International Journal of Electrical and Electronics Engineering* .
16. A.Kargar, F.Sayadi, and J.Soltani, (2011). "Optimal capacitor placement in harmonic distribution systems for voltage regulation and loss reduction with PSO", *Journal of Electrical Eng.* Vol. 41, No.1.
17. H-C. Chang, C-C. Kuo, (1994). "Network Reconfiguration in Distribution Systems using Simulated Annealing", *Electric Power Research*, Vol. 29, pp. 227-238.
18. A.Farhangfar, S.J.Sajjadi, and S.Afsharnia, (2004). "Power Flow Control and Loss Minimization With Unified Power Flow Controller (UPFC)", *Canadian Conference on Electrical and Computer Engineering*, Vol. 1, pp. 385 - 388
19. N.A.Belyaev, N.V.Korovkin, V.S.Chudny, and O.V. Frolov, (2015). "Reduction of active power losses in electric power systems with optimal placement of FACTS devices," in *Young Researchers in Electrical and Electronic Engineering Conference (EIconRusNW)*, IEEE NW Russia, pp. 150-154
20. J. Zhang and A. Yokoyama, (2006). "A comparison between the UPFC and the IPFC in optimal power flow control and power flow regulation," in *Power Symposium, 38th North American*, pp. 339-345.
21. M. M. A. Khabbaz, (2014). "Transmission power loss reduction using intelligent techniques-regulated IPFC," *Energy Conversion (CENCON)*, IEEE Conference on, pp. 423 - 428.